

**Purpose:** The Office Professional Zoning District is primarily designed to accommodate the development of professional offices within close proximity to neighborhoods or areas in transition between residential and commercial.

**GREENWOOD**  
City/County Planning Department

**OP**

**OFFICE PROFESSIONAL DISTRICT**

**Development Standards for Office/Professional Uses:**

Minimum Site Area: 10,000 square feet  
Minimum Building Footprint: 2,500 square feet on the ground level (retail and service establishments)

Minimum Yards: Front: 20 feet  
Side: 10 feet  
Rear: 25 feet

Maximum Impervious Surface Ratio: 65 percent  
Maximum Height of Buildings: 80 feet

**Permitted and Conditional Uses:**

This district allows many types of Architect/Engineer Office, Church, Temple, Synagogue, Community/Neighborhood Recreation, Financial Stock Broker, Interior Design Studio, Law Office, Medical/ Dentist /Doctor Office, Private Recreation Area, Professional Office, Single Family Detached Dwelling, Bed & Breakfast, Business Services-General, Child / Adult Care, Museum/Art Gallery

**Development Standards for Office/Professional Uses**

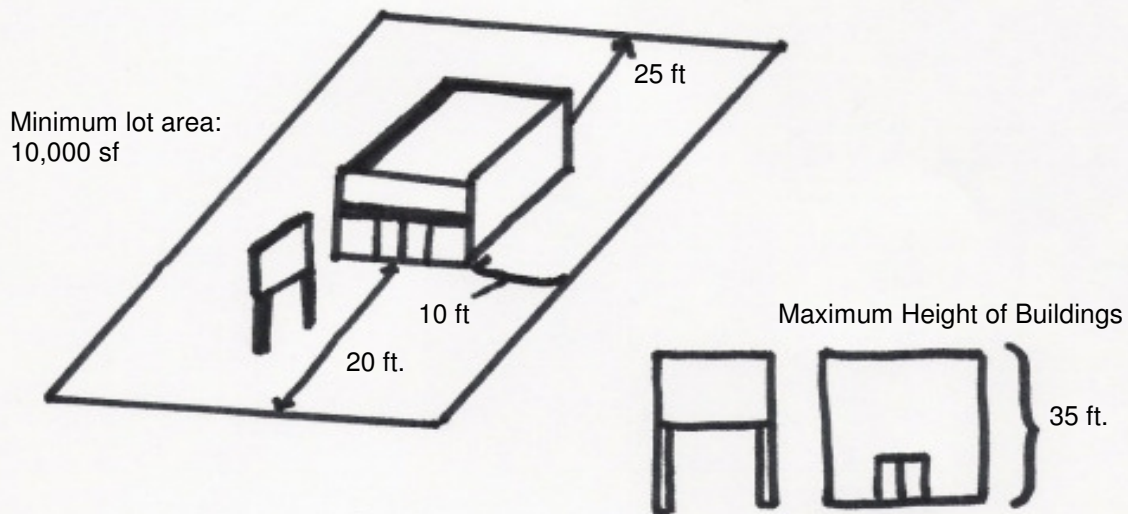

**The City of Greenwood Zoning Regulations**

Note: Drawings are for illustrative purposes only. The text of the ordinance shall prevail over any inconsistency.